



6V

3Ah

SLA

AGM

6SB3P

Rechargeable AGM Sealed Lead Acid Battery

SPECIFICATIONS

Nominal Voltage	6V	
Nominal Capacity		
20 hour rate (0.150A to 5.25V)	3Ah	
10 hour rate (0.285A to 5.25V)	2.85Ah	
5 hour rate (0.510A to 5.1V)	2.55Ah	
1C (3.0A to 4.8V)	1.7Ah	
3C (9.0A to 4.8V)	1.2Ah	
Weight	Approx. 670g	
Internal Resistance (at 1KHz)	Approx. 18mΩ	
Maximum Discharge Current (5 secs)	45A	
Charge Methods at 25°C		
Cycle Use		
Charging Voltage	7.20V to 7.50V	
Coefficient -5.0mV/°C/Cell		
Maximum Charging Current	0.9A	
Standby Use		
Float Charging Voltage	6.75V to 6.90V	
Coefficient -3.0mV/°C/Cell		
Operating Temperature Range		
Charge	-15°C to 40°C	
Discharge	-15°C to 50°C	
Storage	-15°C to 40°C	
Charge Retention (Shelf Life) at 20°C		
1 month	92%	
3 months	90%	
6 months	80%	
Case Material	ABS UL94 HB	
Termination	F1 (Faston Tab 187)	
Design Life	3-5 years	
Classified as a non-spillable battery. Approved for transportation by:		
• Air (IATA/ICAO provision A67)		
• Road		
• Sea (per IMDG Special Provision 238)		



9319632520567



DIMENSIONS

mm (inch)

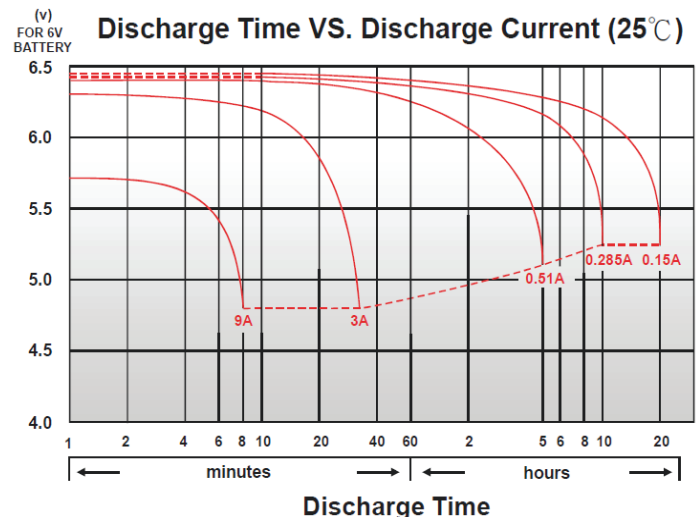
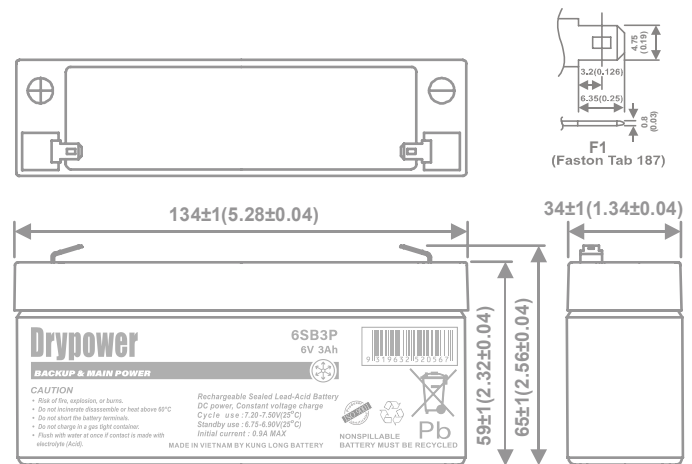

CHARACTERISTICS CHARTS

Effect of Temperature on Capacity 25°C (77°F)

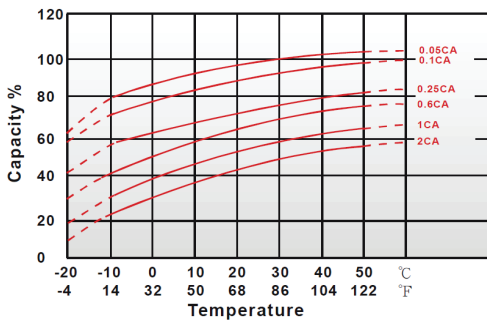

Capacity Retention Characteristic

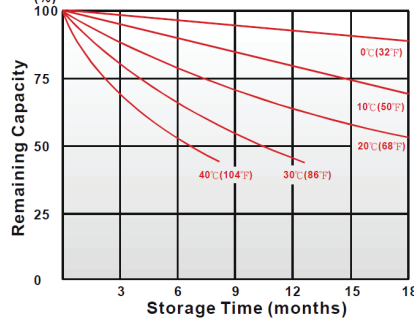

Cycle Service Life

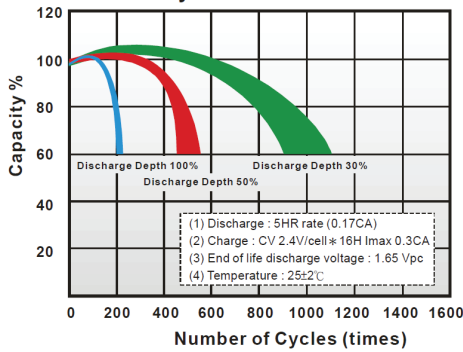

Trickle (or float) Service Life

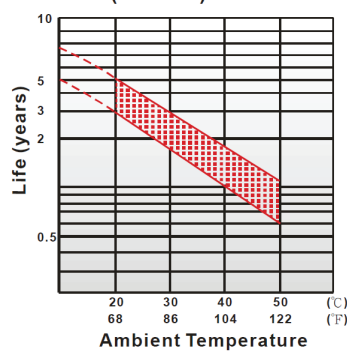

FEATURES & BENEFITS

- ◆ Industry leading 99.99% pure lead content for superior service life and dependable performance.
- ◆ Maintenance free technology and non-spillable design.
- ◆ Excellent charge retention in storage.
- ◆ Higher percentage of tin content compared with the industry standard. Tin extends battery standby life by minimising sulphation (corrosion) especially at higher temperatures.
- ◆ Manufactured by Kung Long Battery (KLB) at facilities in Taiwan and Vietnam.

KLB is a leading manufacturer and complies with relevant international quality standards including ISO9001, CE ETL9000, UL1989, OHSAS18001 and ISO17025.

KLB supports Green Sustainable supply chain practices.



PERFORMANCE DATA

Discharge Rates in Watts to Various End Voltages at 25°C (77°F)

End Voltage		1.85V	1.80V	1.75V	1.70V	1.67V	1.65V	1.60V
Time								
5	min	14.9	16.8	18.2	19.3	20	20.5	21.2
10	min	11.4	12.4	13.3	14	14.4	14.7	15
15	min	8.63	9.61	10.1	10.6	10.9	11.2	11.5
30	min	5.03	5.51	5.82	6.18	6.32	6.43	6.53
60	min	2.88	3.2	3.43	3.63	3.73	3.79	3.88
120	min	1.7	1.85	1.99	2.12	2.19	2.26	2.35
180	min	1.27	1.46	1.56	1.63	1.66	1.7	1.77
240	min	0.968	1.09	1.17	1.21	1.23	1.27	1.33
300	min	0.823	0.926	0.994	1.03	1.05	1.07	1.1
600	min	0.547	0.582	0.597	0.608	0.62	0.62	0.628
1200	min	0.299	0.309	0.317	0.32	0.322	0.324	0.33

Discharge Rates in Amperes to Various End Voltages at 25°C (77°F)

End Voltage		1.85V	1.80V	1.75V	1.70V	1.67V	1.65V	1.60V
Time								
5	min	7.95	9.24	10.3	11.1	11.5	12	12.6
10	min	5.87	6.52	7.07	7.46	7.62	7.79	8.08
15	min	4.49	5.03	5.37	5.71	5.86	6.02	6.23
30	min	2.56	2.87	3.03	3.1	3.12	3.14	3.17
60	min	1.54	1.72	1.81	1.88	1.92	1.94	1.99
120	min	0.945	0.993	1.04	1.08	1.1	1.12	1.15
180	min	0.679	0.718	0.752	0.786	0.807	0.826	0.861
240	min	0.56	0.581	0.604	0.625	0.634	0.646	0.663
300	min	0.472	0.493	0.511	0.526	0.533	0.542	0.554
600	min	0.273	0.289	0.301	0.306	0.308	0.311	0.313
1200	min	0.147	0.154	0.158	0.161	0.163	0.165	0.167

All data on the spec. sheet is an average value:

The tolerance range : X < 6min (+15%~-15%), 6min ≤ X < 10min (+12%~-12%), 10min ≤ X < 60min (+8%~-8%), X ≥ 60min (+5%~-5%)

Aug2020

Performance may vary depending on application. All specifications are correct at time of creation. All specifications and operation conditions contained in this datasheet are subject to change or improvement without prior notice to the user. This data is for evaluation purposes only. No guarantee is intended or implied by this data. For clarification and updated information, please contact us.